

Top Hats

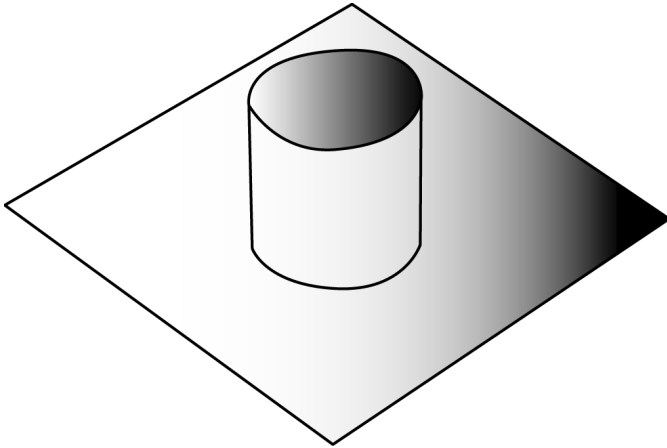

Universal Top Hats



- ◆ Seals pipe penetrations
- ◆ Easy to install
- ◆ High Performance DPC
- ◆ Compatible with all DPCs, Tanking Membranes and DPMs
- ◆ Range of standard pipe sizes
- ◆ Specials to order
- ◆ Gas Resistant and Radon Resistant

A range of Top Hats ideal for sealing pipe penetrations within brick, block, stone or concrete. These units are manufactured from a high performance polymeric membrane and individually electronically tested.

The base flange allows for 100mm overlap with any membrane system and an up-stand normally of 100mm is allowed for sealing to the pipe. When used vertically, as in retaining walls, Top Hats can be back-filled without further protection and form an integral part of any tanking system.

A suitable bituminous mastic is applied to the interface between the pipe and substrate. The Top Hat is then positioned and sealed to the pipe using a butyl or bituminous tape.

