

Preformed Units for use with High Performance DPCs, Cavity Trays & Tanking Systems

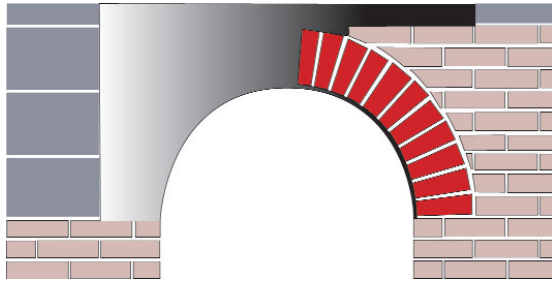

Preformed Arch Cloak

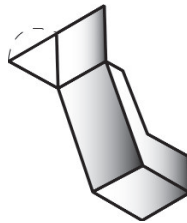

Stop End
SF or Brick/Block

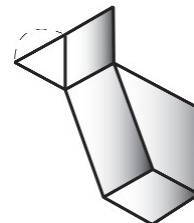

Column Stop End
SF or Brick/Block

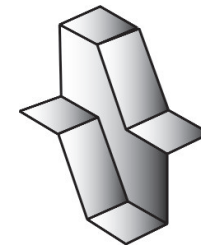

Change of Level
Brick/Block

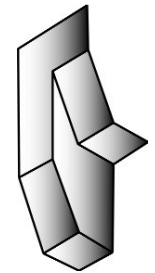

Change of Level
Surface Fix

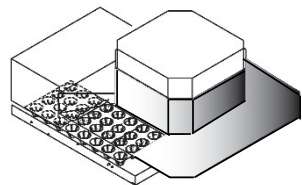

Two Part Column Unit

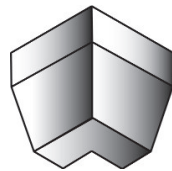

Internal Corner Surface Fix

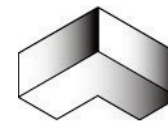

Internal Corner

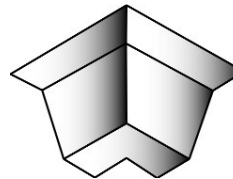

Int/Ext Corner Brick/Block

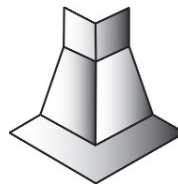

External Corner Surface Fix

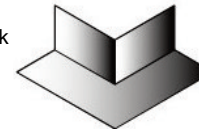

External Corner

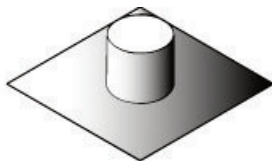

Top Hat Unit

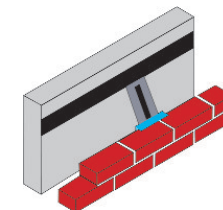

Joint Support in Position

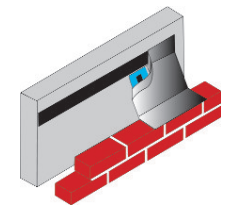

Cavity Tray Bonded to
Joint Support

Non Standard Units to Order

Call for Quotation
0845 226 3186

D-Sign Limited, PO Box 186 Ware, SG12 7ZT
www.d-signgroup.com

Preformed Units - Non Standard Units to Order

- Available in black, brown or white to suit facing brickwork or stonework.

- Standard Rolls 20m long in following widths in mm:-

100	337.5
112.5	450
150	600
225	900
300	

- Standard preformed units for use as cavity tray system.

- High frequency welded, eliminating risk of leakage paths associated with site forming.

- Any shape or profile designed.

- Preformed units available to include detailing at intersections between below ground tanking systems and pipe penetration details.

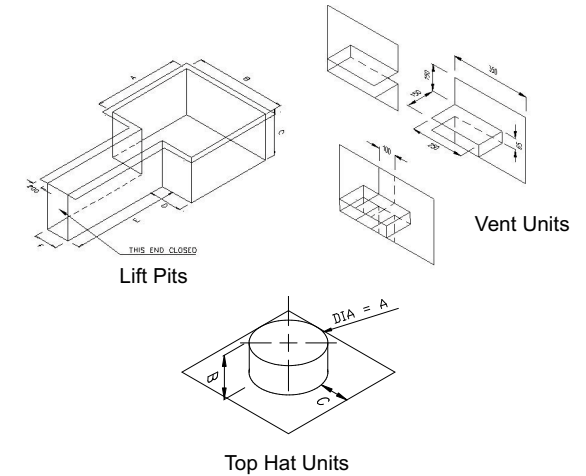
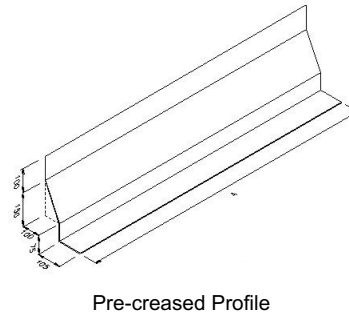
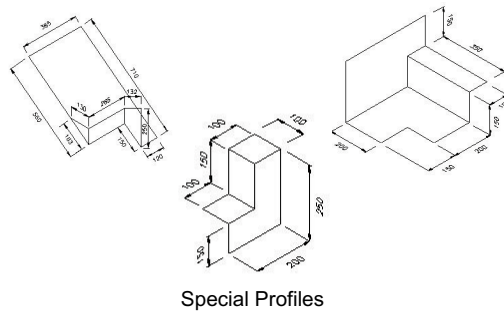
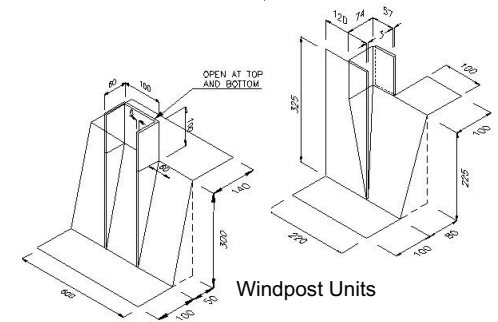
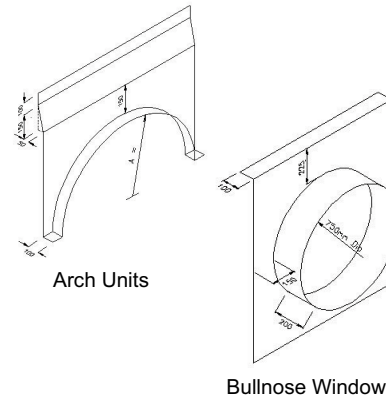
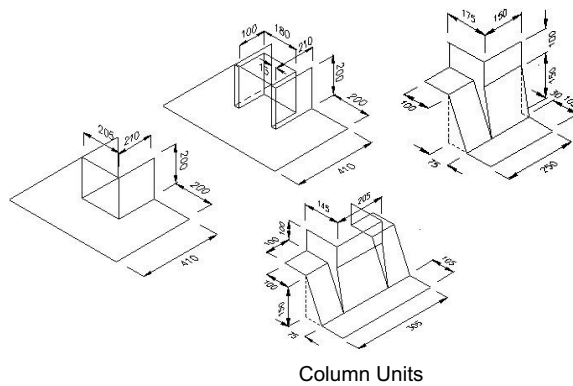

Preformed Units - Standard Units to Order

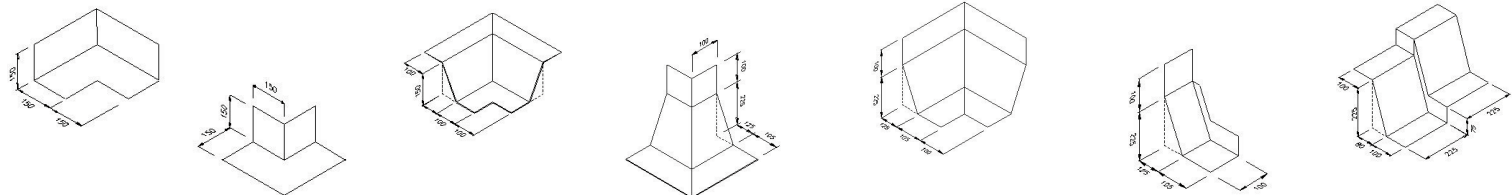

Call for Quotation
0845 226 3186